

OVERVIEW

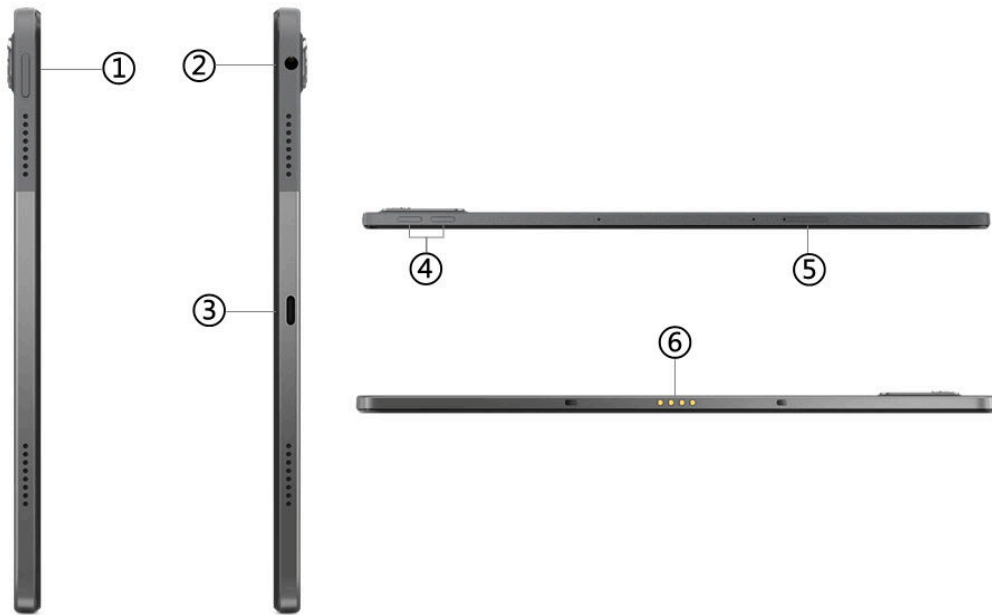

1. Power button	4. Volume buttons
2. Headphone / microphone combo jack (3.5mm)	5. Card slot
3. USB-C 2.0	6. Pogo pin connector (4-point)

Notes:

- Card slot is for microSD card (WLAN model) or nano-SIM + microSD card (WWAN model)

PERFORMANCE

Processor

Processor Family

MediaTek Processor

Processor

Processor Name	Cores	Max Frequency	Processor Graphics
MediaTek Helio G99	Octa-core 2x A76 + 6x A55	A76@2.2GHz / A55@2.0GHz	ARM Mali-G57 MC2 GPU

Operating System

Operating System^[1]

Android™ 12L or later

Notes:

[1] The operating system at launch is Android 12L. Two major OS upgrades (up to Android 14) will be made following launch during the product's lifecycle and it will receive three years of security upgrades. For the latest software upgrade information, please visit <https://support.lenovo.com/solutions/ht501098>.

Graphics

Graphics

Graphics	Type	Memory
ARM Mali-G57 MC2 GPU	Integrated	Shared

Chipset

Chipset

MediaTek SoC (System on Chip) platform

Memory

Max Memory

- 4GB soldered memory, not upgradable
- 6GB soldered memory, not upgradable

Memory Type

LPDDR4x

Storage

Storage Support

- 64GB uMCP (UFS-Based MCP, UFS 2.2)
- 128GB uMCP (UFS-Based MCP, UFS 2.2)
- microSD card, supports up to 1TB (exFAT)

Storage Type

Disk Type	Interface	Offering
Flash Memory	UFS 2.2	64GB / 128GB

Removable Storage

Card Reader**

- Nano-SIM + microSD card slot (WWAN models)
- microSD card slot (WLAN models)

Multi-Media

Speakers

4 speakers, 1W x4, optimized with Dolby® Atmos®

Microphone

Dual-microphone array

Camera

Tab P11(2nd Gen)

Front 8.0MP, f/2.0, 83° FoV (field of view) fixed focus, face unlock, video recording 1080P@30fps
 Rear 13.0MP, f/2.4, 89° FoV, video recording 1080p@30fps, autofocus; single LED flashlight

VoiceCall

- Voice call^[1]
- No support

Notes:

[1] Use of Voice call requires cellular data plan. Voice call functionality details may vary based on local operator network, data and messaging services. Please contact your carriers for details.

Sensor

Vibration Motor

Eccentric Rotating Mass (ERM)

Sensors

- Accelerometer (G) sensor
- Ambient light sensor (ALS)
- Coulomb counter
- Gyroscope sensor
- Hall sensor
- Proximity (P) sensor

Battery

Battery

Integrated Li-Polymer 7500mAh (minimum) / 7700mAh (typical) battery

Max Battery Life^[1]

Online video playback: 10 hr

Web browsing: 10 hr

Music playback: 31 hr

Charging Time^[2]

Around 3 hr to fully charged

Notes:

[1] All battery life claims are approximate and based on internal testing under optimal laboratory and network conditions. Actual battery performance will vary depending on numerous factors including product configuration and usage, software, operating conditions, wireless functionality, power management settings, screen brightness and other factors. The maximum capacity of the battery will naturally decrease with time and usage.

[2] Charging data claim is approximate and based on internal testing under optimal laboratory. Actual result may vary owing to differences in product configuration, usage, software, operating conditions and other factors.

Power Adapter

Power Adapter

- 10V/2A (20W) AC adapter, 100-240V, 50-60Hz
- No power adapter

DESIGN

Display

Display^{[1][2]}

Size	Resolution	Touch	Type	Brightness	Surface	Aspect Ratio	Contrast Ratio	Color Gamut	Refresh Rate	Viewing Angle (L/R/U/D)	Key Features
11.5"	2K (2000x1200)	Multi-touch	IPS	400nits	Anti-fingerprint	15:9	1400:1	97.5% DCI-P3	120Hz	80°/80°/80°/80°	204 PPI, 86% screen-to-display ratio, Corning® Gorilla®

WCDMA: B1/B2/B4/B5(B6/B19)/B8
 FDD LTE: B1/B2/B3/B4/B5/B7/B8/B12/B13/B18/B19/B20/B25/B26/B28(a+b)/B66
 TDD LTE: B38/B40/B41 (2496 MHz-2690 MHz)

Wi-Fi Direct

Support

Wi-Fi Display

Support

Location Services**

Models	Location
WLAN models	No location service
WWAN models	GPS + GLONASS + Galileo + Beidou + A-GPS

Notes:

[1] Wi-Fi 6E full features might be limited by country-level restrictions. 6GHz Wi-Fi 6E operation is dependent on the support of routers/APs/Gateways that support Wi-Fi 6E, and the regional regulatory certifications & spectrum allocation.

Ports^[1]

Standard Ports

- 1x Card slot
- 1x Headphone / microphone combo jack (3.5mm)
- 1x Pogo pin connector (4-point)
- 1x USB-C® 2.0 (support data transfer and charging)

Notes:

[1] The transfer speed of following ports will vary and, depending on many factors, such as the processing speed of the host device, file attributes and other factors related to system configuration and your operating environment, will be slower than theoretical speed.

- USB 2.0: 480 Mbit/s;
- USB 3.2 Gen 1 (SuperSpeed USB 5Gbps, formerly USB 3.0 / USB 3.1 Gen 1): 5 Gbit/s;
- USB 3.2 Gen 2 (SuperSpeed USB 10Gbps, formerly USB 3.1 Gen 2): 10 Gbit/s;
- USB4® 20Gbps / USB 3.2 Gen 2x2 (SuperSpeed USB 20Gbps): 20 Gbit/s;
- USB4 40Gbps (USB 40Gbps): 40 Gbit/s;
- Thunderbolt™ 3/4: 40 Gbit/s.

Docking

Docking

- Lenovo Keyboard Pack for Tab P11 (2nd Gen)
 Keyboard: 272.45 x 172.7 x 5.5 mm (10.73 x 6.8 x 0.22 inches), starting at 267g (0.59 lbs)
 Stand (without pouch area): 273.45 x 173.7 x 5.1 mm (10.77 x 6.84 x 0.2 inches), starting at 295 g (0.65 lbs)
 Stand (with pouch area): 273.45 x 189.5 x 5.1 mm (10.77 x 7.46 x 0.2 inches), starting at 295 g (0.65 lbs)
- No keyboard docking inbox

SERVICE

Warranty

Base Warranty^[1]**

- 1-year carry-in service
- 1-year mail-in service
- 1-year courier service
- 2-year (1-yr battery) mail-in service
- 2-year (1-yr battery) carry-in service
- 2-year (2-yr battery) carry-in service
- 2-year (1-yr battery) courier service
- 2-year (2-yr battery) courier or carry-in service
- 3-year (1-yr battery) courier service

Notes:

[1] For warranty upgrade service, please go to <https://smartfind.lenovo.com/services>. To learn more details of warranty policy, please access <https://pcsupport.lenovo.com/warranty>.

ENVIRONMENTAL

Operating Environment

Temperature

Operating: 0°C (32°F) to 40°C (104°F)

ACCESSORIES

Bundled Accessories

Bundled Accessories**

- Folio case
- Smart Charging Station 2 (4-point pogo-pin charging connector)
- None

SOFTWARE

Preinstalled Software

Preinstalled Software^{[1][2]}

- Entertainment Space
- Chrome
- Gmail
- Google
- Google Play
- Google Sheets
- Google TV
- Google Photos
- Google Podcasts
- Google One
- Google Docs
- Google Duo
- Google Drive
- Google Kids Space
- Google Maps
- Files by Google
- Messages
- Recorder
- YouTube
- YouTube Kids
- YouTube Music
- Lenovo Freestyle
- Lenovo Instant Memo
- MyScript® Calculator
- Nebo®
- Netflix
- Tablet Center

Notes:

[1] Actual application availability varies by country/region.

[2] Books and video content not available in all regions. Video content subject to availability of YouTube Kids app. Books content requires the Play Books app. Availability of apps, books, and video content may change without notice. Google Assistant not available in Google Kids Space. Google Kids Space requires a Google Account for your child. Parental controls require the Family Link app on a supported Android, Chromebook, or iOS device.

CERTIFICATIONS

Green Certifications^[1]

Green Certifications

- (Optional) ENERGY STAR® 8.0
- ErP Lot 3
- RoHS compliant

Notes:

[1] The items listed under the "Green Certifications" section may not only refer to certification but also registration or self-declaration.

Other Certifications

Dust and Water Resistant

IP52

Other Certifications

TÜV Rheinland® Full Care Display Certification

- Feature with ** means that only one offering listed under the feature is configured on selected models.
- Lenovo reserves the right to change specifications or other product information without notice. Lenovo is not responsible for photographic or typographical errors. LENOVO PROVIDES THIS PUBLICATION "AS IS," WITHOUT WARRANTY OF ANY KIND, EITHER EXPRESS OR IMPLIED, INCLUDING THE IMPLIED WARRANTIES OF MERCHANTABILITY OR FITNESS FOR A PARTICULAR PURPOSE. Some jurisdictions do not allow disclaimer of express or implied warranties in certain transactions, therefore this disclaimer may not apply to you.
- The specifications on this page may not be available in all regions, and may be changed or updated without notice.

